

MOTOR SPECIFICATION SHEET

MODEL : SC-QR 1/2HP 4P

USED FOR : STANDARD

DESCRIPTION	DETAIL			
PHASE	1			
TYPE	CAPACITOR START			
MODEL NAME	SC-QR			
RATED OUTPUT, HP (kW)	1/2 (0.4)			
POLE	4			
CODE	MEATH CODE : 1M001C-400040QRER2			
OUTLINE DRAWING NO.	ONM84O092-*			
RATED VOLTAGE (V)	220	230	220	
RATED FREQUENCY (Hz)	50	50	60	
RATED CURRENT (A)	4.3	4.3	3.6	
RATED SPEED (min ⁻¹)	1430	1430	1720	
RATED EFFICIENCY (%)	70.0	70.4	72.7	
THERMAL CLASS	120(E)			
RATING	S1 (CONTINUOUS)			
ENCLOSURE CONSTRUCTION	OPEN-PROTECTED			
DEGREES OF PROTECTION	IP20			
METHOD OF COOLING	IC01			
FRAME NO.	80M			
WEIGHT (kg)	11.5			
STANDARD	JEC-2137-2000			
EFFICIENCY RULE	IEC 60034-30-1			
INSTALLATION	FOOT MOUNTED			
ROTATION	CCW (VIEWED FROM SHAFT END)			
BEARING	LOAD SIDE : 6203ZZ			
	OPPOSITE SIDE : 6202ZZ			
BEARING GREASE	UREA GREASE			
VIBRATION	V20			
CIRCUMSTANCE CONDITION	AMBIENT TEMPERATURE : -20 ~ +40°C			
	AMBIENT HUMIDITY : 85%RH OR LESS			
	ABOVE SEA LEVEL : 1000m OR LESS			
	ENVIRONMENT : NO BURSTING/EROSIVE GAS OR VAPOR			
COLOR	MUNSELL N1.5 (BLACK)			
TERMINAL BOX	NO. OF LEAD WIRES : 2			
	SOURCE CONNECTION : TERMINAL BLOCK			
INSULATION RESISTANCE	BY DC 500V MEGGER - ≥100MΩ			
DIELECTRIC TEST	AC 50Hz 1500V - 1min. (Based on rated voltage 220V)			
SHAFT SWING	≤0.03mm			
MATERIAL	FRAME : STEEL PLATE			
	BRACKET : ALUMINIUM			
	SHAFT : CARBON STEEL			
	STATOR CORE : ELECTRICAL STEEL			
	WIRE : ENAMELLED COPPER MAGNET WIRE			
	INSULATOR : POLYESTER FILM			
	VARNISH : EPOXY DENATURALIZATION POLYESTER			
	ROTOR CORE : ELECTRICAL STEEL			
	CONDUCTOR : ALUMINIUM			
	TERMINAL BOX : PLASTIC			
	PAINTING : ALKYD-NITROCELLULOSE RESIN			
PRODUCTION COUNTRY	THAILAND			

Specifications subject to change without notice.

SPECIFICATION SHEET NO.				
SS-M-8302-B				

MODEL SC-QR SINGLE PHASE INDUCTION MOTOR OUTLINE DRAWING

CAPACITOR START TYPE
DEGREE OF PROTECTION IP20

STARTING CAPACITOR	80 μ F 250 V
RUNNING CAPACITOR	-

CUSTOMER _____
USER _____
FOR _____
CUSTOMER'S ORDER NO. _____
QUANTITY _____
MFG. ORDER NO. _____

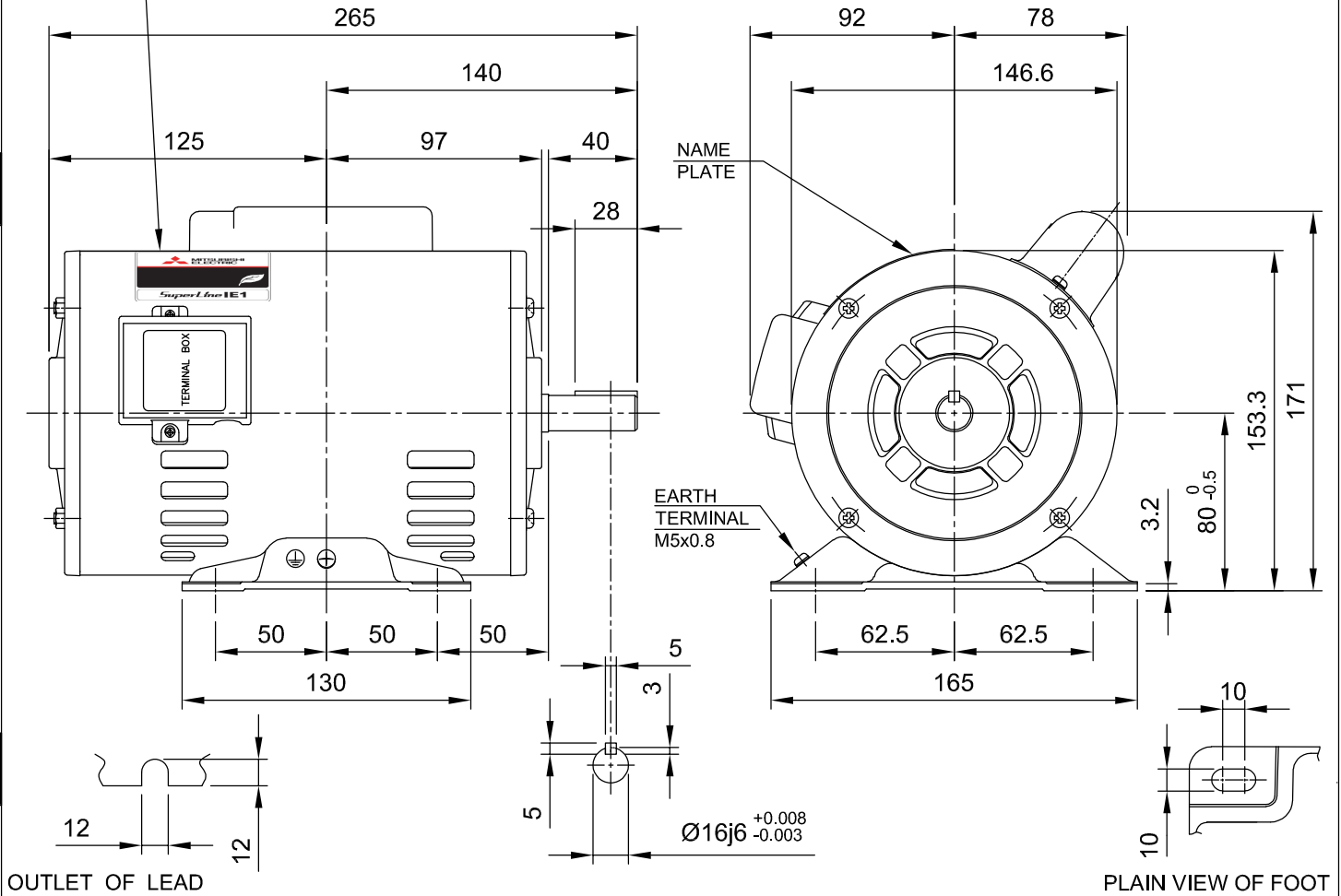

FRAME SIZE	RATING	TH. CLASS	AMB. TEMP.	BEARINGS		COLOR	DIRECTION OF ROTATION	NO. OF LEAD WIRES
				LOAD SIDE	OPP. SIDE			
80M	S1	120(E)	40°C	6203ZZ	6202ZZ	BLACK (MUNSELL N1.5)	CCW	TERMINAL BOARD

OUTPUT		POLE	Hz	VOLT	AMP	RPM	IE CODE - RATED EFF.	REMARK
HP	kW							
1/2	0.4	4	50	220/230	4.3/4.3	1430/1430	IE1- 70.0% / IE1- 70.4%	
			60	220	3.6	1720	IE1- 72.7%	

MITSUBISHI ELECTRIC AUTOMATION (THAILAND) CO.,LTD.

		OUTLINE DRAWING NO.	REV.
	DIMENSION IN mm.	ONM840092	
	SCALE : NTS.		